

DRAWING MADE IN THIRD ANGLE PROJECTION
 THIS DRAWING IS UNPUBLISHED. RELEASED FOR PUBLICATION .19
 © COPYRIGHT 19 BY AMP INCORPORATED. ALL INTERNATIONAL RIGHTS RESERVED.

PRD		LOC		DST		REVISIONS		DATE	APPD
CODE	DF	DO	P	F	ZONE	LTR	DESCRIPTION		
5064	DF	DO				N	REDRAWN & REVISED PER DF-3808	BR	10-20-90

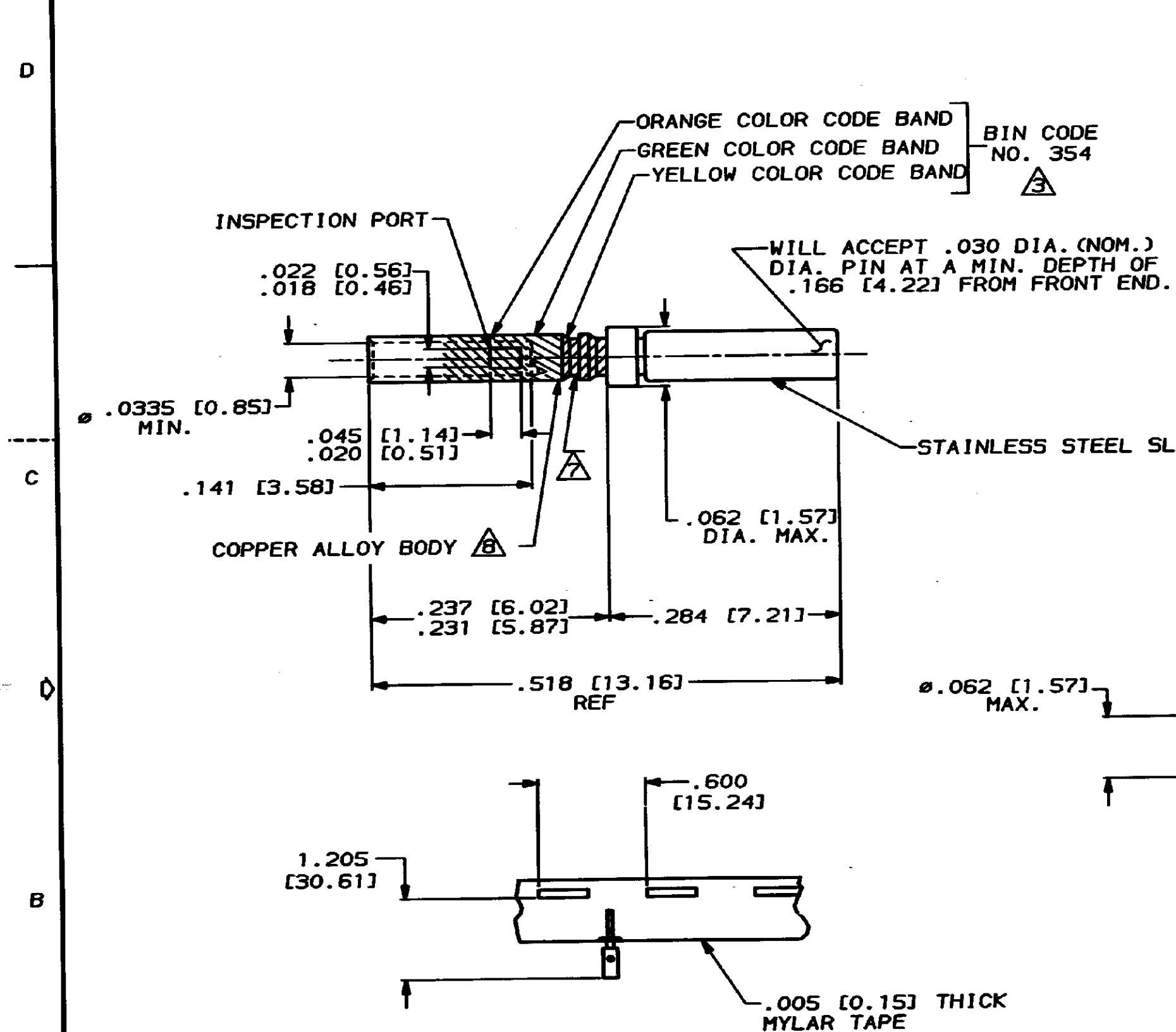

1. WIRE BARREL WILL ACCEPT #22-28 AWG WIRE.
2. CRIMPING TOOL- USE MS3198-1 WITH APPLICABLE POSITIONER.
- △ CONTACT CONFORMS TO MIL-C-39029/57, SIZE 22.
4. NET WEIGHT- .102 GRAMS.
5. INSERTION, EXTRACTION TOOL- AMP P/N 91067-1.
- △ THIS CONTACT IDENTIFIED AS MS27491-22 SUPERSEDES M24308/12-1.
- △ IDENTIFICATION GROOVE IS OPTIONAL.
- △ PLATING: GOLD PER MIL-G-45204 OVER NICKEL.

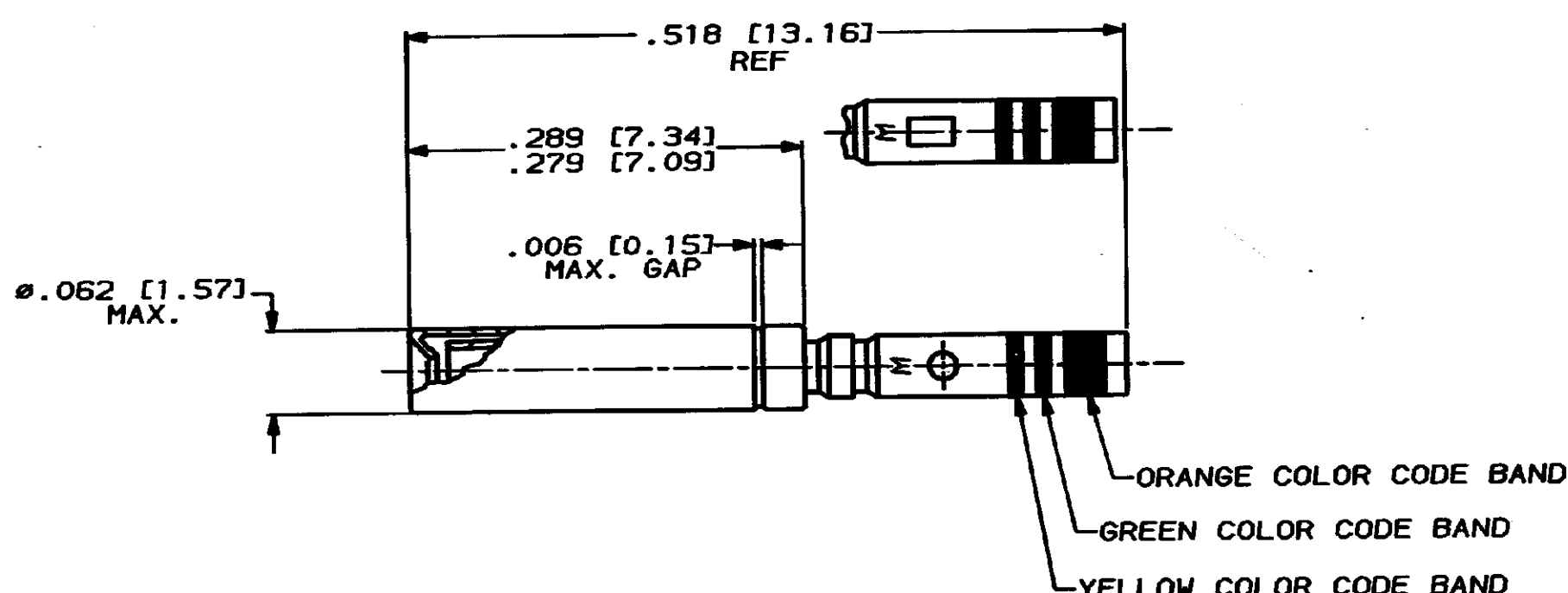

ALTERNATE CONFIGURATION

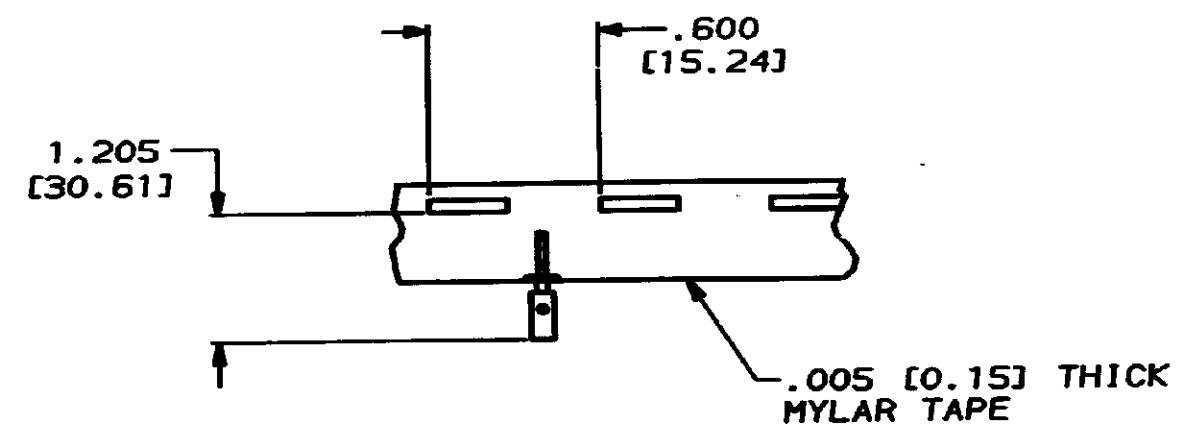

WHEN ORDERING CONTACT ON TAPE, ORDER BY THE TAPE NUMBER PLUS THE PACKAGEING CODE AS FOLLOWS:
 2. FOR USE WITH AMP TAPETRONIC, PNEUMATIC TOOL-
 A. 1000 PARTS TO A BOX ADD PACKAGING CODE: 1MBOX
 3. FOR USE WITH 4/8 INDENT STRIPPER CRIMPER-
 A. 1000 PARTS TO A REEL ADD PACKAGING CODE: 1MREEL
 B. 5000 PARTS TO A REEL ADD PACKAGING CODE: 5MREEL

CONTACTS ON TAPE	SAME AS -1	204351-2
AS SHOWN	△	204351-1
DESCRIPTION	PLATING	PART NO.
DO NOT SCALE PRINT. UNLESS SPECIFIED DIMENSIONS IN INCHES TOLERANCES ON : 2 PLC DEC ± - 3 PLC DEC ± .005 ANGLES ± -	DR 10-5-90 R. RINEHART CHK <i>A. Emoli</i> 10-15-90 APPD <i>A. Emoli</i> 10-15-90 MATERIAL	AMP AMP Incorporated Harrisburg, PA 17105-3608
STATED	APPD <i>R. Rinehart</i> 10-15-90 PRODUCT SPEC	NAME CONTACT ASS'Y, SOCKET SIZE 22D, AMPLIMITE
FINISH	APPLICATION SPEC	SIZE CAGE CODE DRAWING NO C 00779 204351
WEIGHT	SCALE 10:1	SHEET 1 OF 1

CUSTOMER DRAWING